



# Thermal Shut-off IOM

## INSTALLATION & MAINTENANCE FOR LT-SERIES ASSEMBLIES

### I. OVERVIEW OF FUSIBLE LINK ASSEMBLIES

BI-TORQ Valve Automation’s Thermal Shut-off valves (also known as fusible link valves) are designed for flow shutoff protection in piping systems handling flammable gasses or liquids, solvents, toxic fluids, or any other potentially dangerous media. These fire control valves terminate flow in the event of fire, aiding in reducing fire intensity. In the event of fire, the fusible link separates, allowing the top mounted spring pack to drive an API 607 fire safe rated valve into a closed position. Fusible links are available in a range of temperature settings. The thermal shut-off valve assembly also is available in a fail open position, ideal for a fire suppression system applications.

The product you have received has been assembled and tested at our factory with attention to safety in mind. BI-TORQ uses high quality materials and tested engineering to ensure that this product will operate safely and reliably. Carefully read all instructions before handling in order to avoid injury to the operator or damage to the product.

NOTE: Please refer to the attached assembly drawing FL-LT-0600 for parts identification.

### II. GENERAL SAFETY INSTRUCTIONS

**WARNING:** This fusible link assembly has been shipped from the factory in the armed position and is ready for installation in line. Use extreme caution in handling the assembly because the spring pack is under full tension at all times.

For shipping purposes, the fusible link has been replaced with a safety link (#9). This part can be identified as the part that is PAINTED RED. (see illustration 2.1)

safety link (painted red)

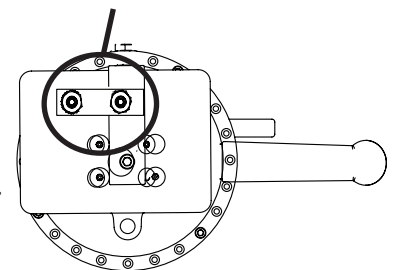

**IMPORTANT:** THE SAFETY LINK MUST BE REMOVED AND REPLACED WITH THE FUSIBLE LINK AFTER THE VALVE HAS BEEN PUT IN LINE. IF SAFETY LINKS ARE NOT REMOVED, FUSIBLE LINK WILL NOT OPERATE CORRECTLY.

The unit must be installed in a location with carefully maintained ambient temperatures. Installing the link in locations where high temperature fluctuations are possible (such as direct sunlight) is not recommended. Exposure to high ambient temperatures can cause the fusible links to break prematurely. (See chart 1 for link temperature ratings.)

chart 1

Part Number	Yield Temp	Max. Ambient Temp.
FL-1-165	165° F / 74° C	135° F / 57° C
FL-1-212	212° F / 100° C	185° F / 82° C
FL-1-286	286° F / 138° C	253° F / 123° C
FL-1-360	360° F / 182° C	330° F / 166° C



## Thermal Shut-off IOM

### INSTALLATION & MAINTENANCE FOR LT-SERIES ASSEMBLIES

#### III. INSTALLING FUSIBLE LINKS ON THE LOW TORQUE SERIES ASSEMBLY

Please refer to the attached assembly drawing FL-LT-0600 for parts identification and complete parts list.  
NOTE: THE UNIT HAS BEEN SHIPPED IN THE ARMED (OPEN) POSITION WITH A RED SAFETY LINK.

REQUIRED TOOLS: 7/16" and 3/4" open end wrenches

CAUTION: SECURE VALVE IN LINE OR IN A VISE BEFORE LINK INSTALLATION

1. With 3/4" wrench, apply tension on the tripper arm (#7) toward the open position (CCW) to relieve tension on the red safety link (#8).
2. Loosen and remove 1/4" x 20 nuts on link retaining studs (#10) with 7/16" open end wrench.
3. While maintaining tension (CCW) with 3/4" wrench on tripper arm (#7), remove the safety link and replace with the fusible link supplied with the assembly. (see illustration 3.1)
4. Secure link to two retaining (#10) studs with 1/4" x 20 nuts until link is held firmly in position.  
CAUTION: Do not tighten nuts. Tightening will stress the links and could result in improper functioning.
5. Gently release the valve handle until spring tension helped by fusible link. The thermal shut-off assembly is now properly armed.

illustration 3.1

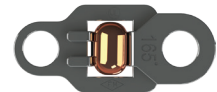

#### IV. OPERATION

Once the unit is properly armed, the valve may be operated closed-open in the normal manner using the valve handle (#5) without disturbing the fusible link.

#### V. MAINTENANCE

Refer to model number and serial number on assembly when ordering replacement parts.

**IMPORTANT:** The fusible link manufacturer recommends annual replacement of link(s) as part of a regular maintenance schedule. Contact your local distributor or AVK Carbo-Bond for replacement links. Order by part number or temperature rating on old link.

Replacement valve seats and seals subject to normal wear are available from your local distributor or BI-TORQ Valve Automation

The spring pack is lifetime lubricated and do not require maintenance. Disassembly of the spring case will void any written or verbal warranties.

**WARNING:** THE SPRING PACK CLOCKSRING IS ALWAYS UNDER TENSION. DO NOT DISASSEMBLE SPRING PACK UNDER ANY CIRCUMSTANCES. DISASSEMBLY OF THE SPRING PACK COULD RESULT IN SERIOUS INJURY OR DEATH.



**INSTALLATION & MAINTENANCE FOR LT-SERIES ASSEMBLIES**

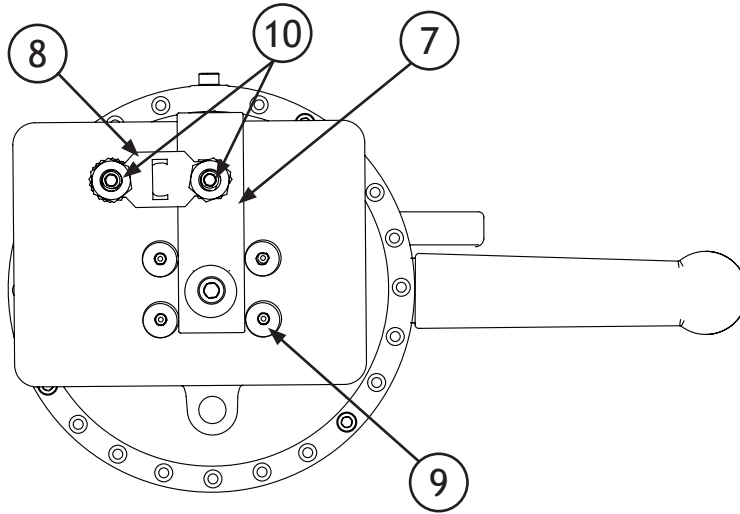

TOP VIEW (ARMED)

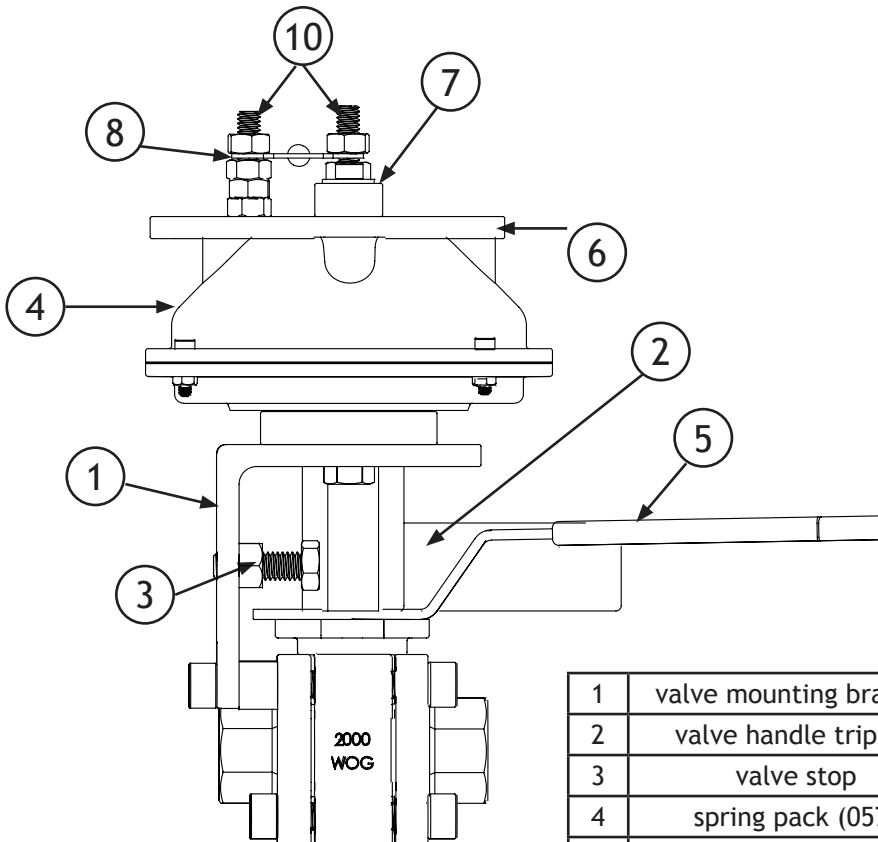

SIDE VIEW

**IMPORTANT: IMPROPER INSTALLATION OR ARMING OF THERMAL SHUT-OFF ASSEMBLIES WILL VOID WARRANTY, AS WILL DISASSEMBLY OF THE PRODUCT WITHOUT PRIOR APPROVAL FROM FACTORY.**

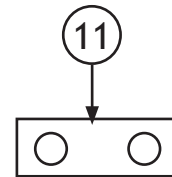

1	valve mounting bracket	7	tripper arm
2	valve handle tripper	8	fusible link
3	valve stop	9	mounting plate fasteners
4	spring pack (057)	10	retaining studs
5	valve handle	11	safety link (for shipping only)
6	mounting plate		

ASSEMBLY DRAWING FL-LT-0600